

Domiled[™]

Synonymous with function and performance, the Domiled[™] series is perfectly suited for a variety of cross-industrial applications due to its small package outline, durability and superior brightness.



Features:

- > High brightness surface mount LED using thin film technology.
- > 120° viewing angle.
- > Small package outline (LxWxH) of 3.2 x 2.8 x 1.8mm.
- > Qualified according to JEDEC moisture sensitivity Level 2.
- > Compatible to IR reflow soldering.
- > Environmental friendly; RoHS compliance.



Applications:

- > Display: full color display video notice board.

Optical Characteristics at Tj=25°C

Part Ordering Number	Color	Viewing Angle°	Luminous Intensity @ 20mA IV (mcd)		
			Min.	Typ.	Max.
DDT-DJE-VW2-1	True Green, 525nm	120	715.0	1125.0	1800.0
DDB-DJE-TU1-1	Blue, 470nm	120	285.0	422.5	560.0

NOTE

1. All part number above comes in a quantity of 2000 units per reel.
2. Other luminous intensity groups are also available upon request.
3. Luminous intensity is measured with an accuracy of ± 11%.
4. Wavelength binning is carried for all units as per the wavelength-binning table. Only one wavelength group is allowed for each reel.
5. An optional Vf binning is also available upon request. Binning scheme is as per following table.

Electrical Characteristics at Tj=25°C

Part Number	Min. (V)	Vf @ If = 20mA		Vr @ Ir = 10uA	
		Typ. (V)	Max. (V)	Min. (V)	
DDx-DJE	2.8	3.2	3.7	5	

Forward voltage, Vf is measured with an accuracy of ± 0.1 V.

Absolute Maximum Ratings

	Maximum Value	Unit
DC forward current	20	mA
Peak pulse current; (tp ≤ 10µs, Duty cycle = 0.005)	200	mA
Reverse voltage	5	V
ESD threshold (HBM)	1000	V
LED junction temperature	125	°C
Operating temperature	-40 ... +100	°C
Storage temperature	-40 ... +100	°C
Power dissipation (at room temperature)	85	mW

Wavelength Grouping at Tj=25°C

Color	Group	Wavelength distribution(nm)
DDT; True Green	Full	520.0 - 535.0
	A	520.0 - 525.0
	B	525.0 - 530.0
	C	530.0 - 535.0
DDB; Blue	Full	464.0 - 476.0
	A	464.0 - 470.0
	B	470.0 - 476.0

Dominant wavelength is measured with an accuracy of ± 1 nm.

Luminous Intensity Group at Tj=25°C

Brightness Group	Luminous Intensity IV (mcd)
T1	285.0...355.0
T2	355.0...450.0
U1	450.0...560.0
V1	715.0...900.0
V2	900.0...1125.0
W1	1125.0...1400.0
W2	1400.0...1800.0

Luminous intensity is measured with an accuracy of ± 11%.

Relative Intensity Vs Forward Current

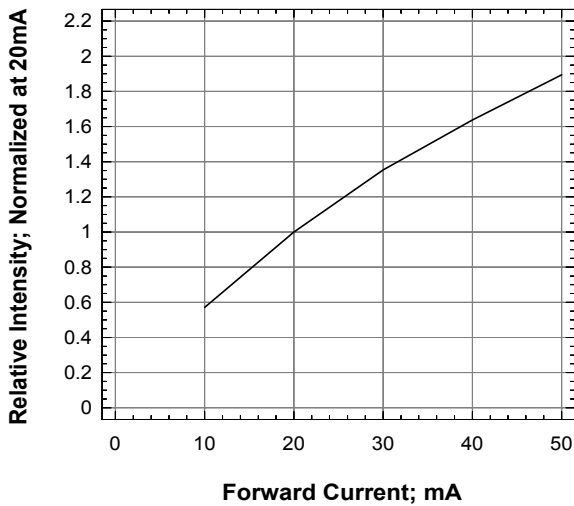

Forward Current Vs Forward Voltage

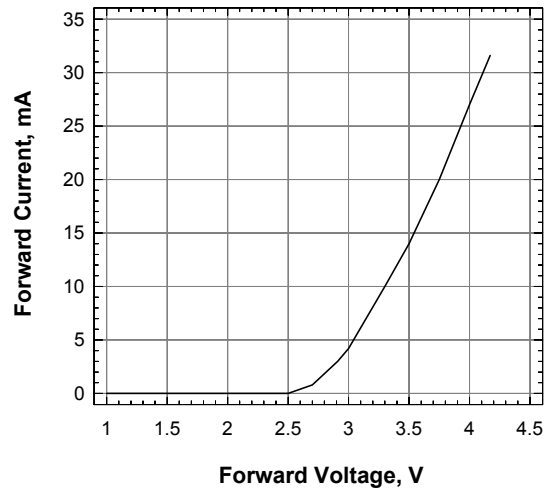

Maximum Current Vs Ambient Temperature

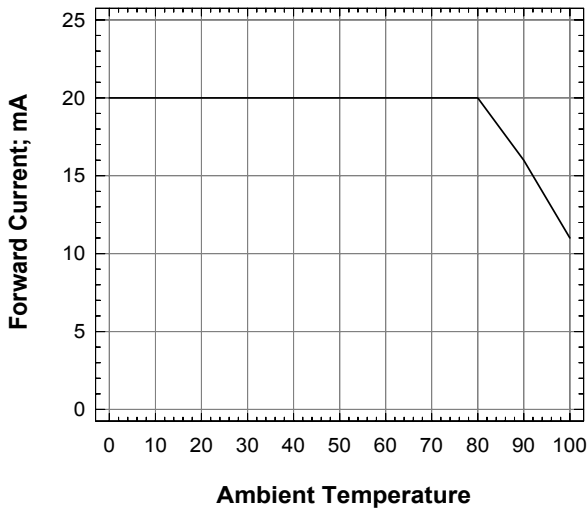

Relative Intensity Vs. Wavelength

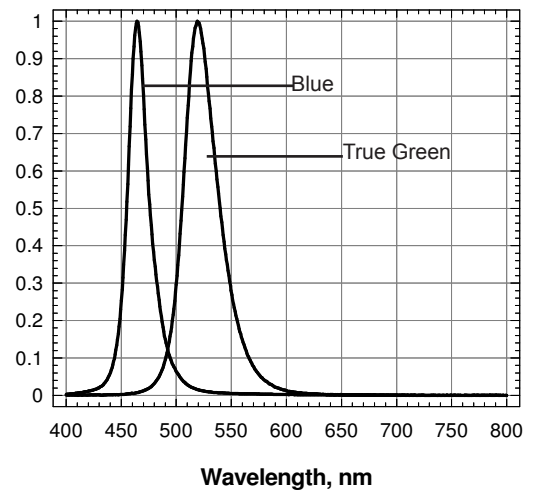

Dominant Wavelength Shift Vs Forward Current

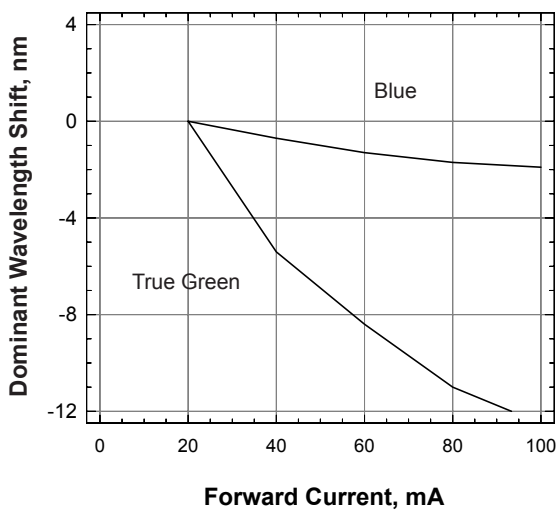

Radiation Pattern

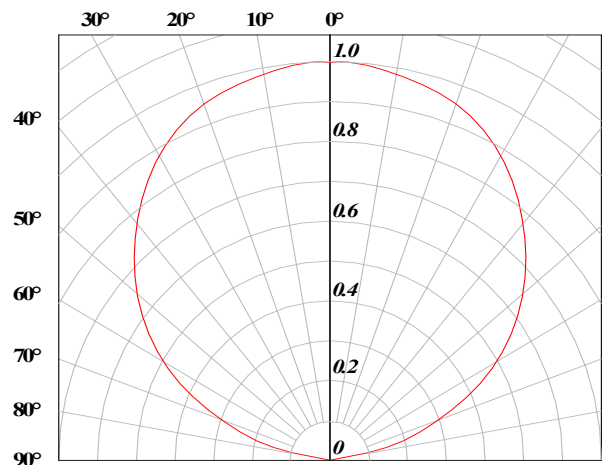

DomiLED™ • InGaN Colored Resin : DDx-DJE Package Outlines

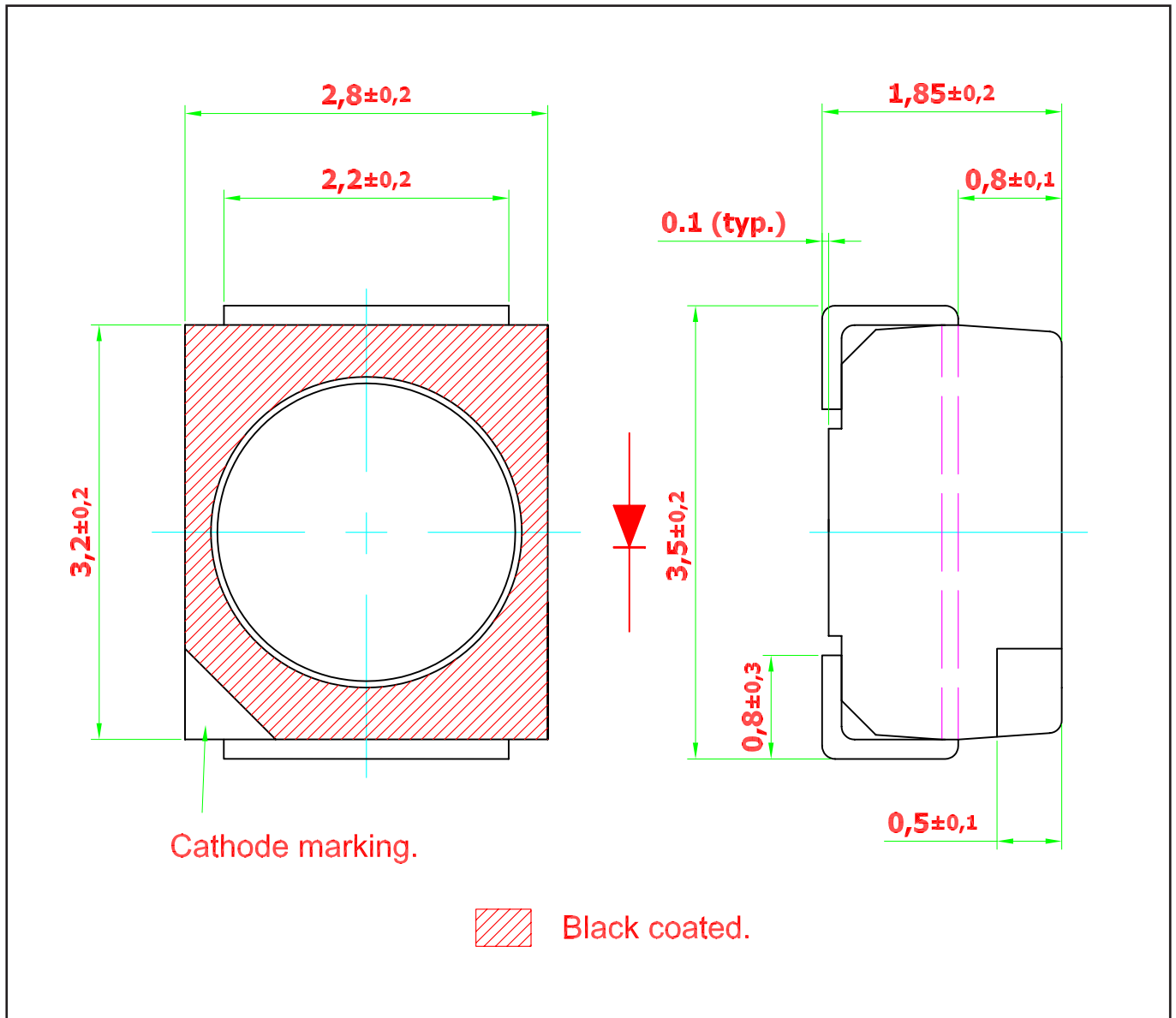

Material

Material	
Lead-frame	Cu Alloy With Ag Plating
Package	High Temperature Resistant Plastic, PPA
Encapsulant	Epoxy
Soldering Leads	Sn-Sn Plating

Recommended Solder Pad

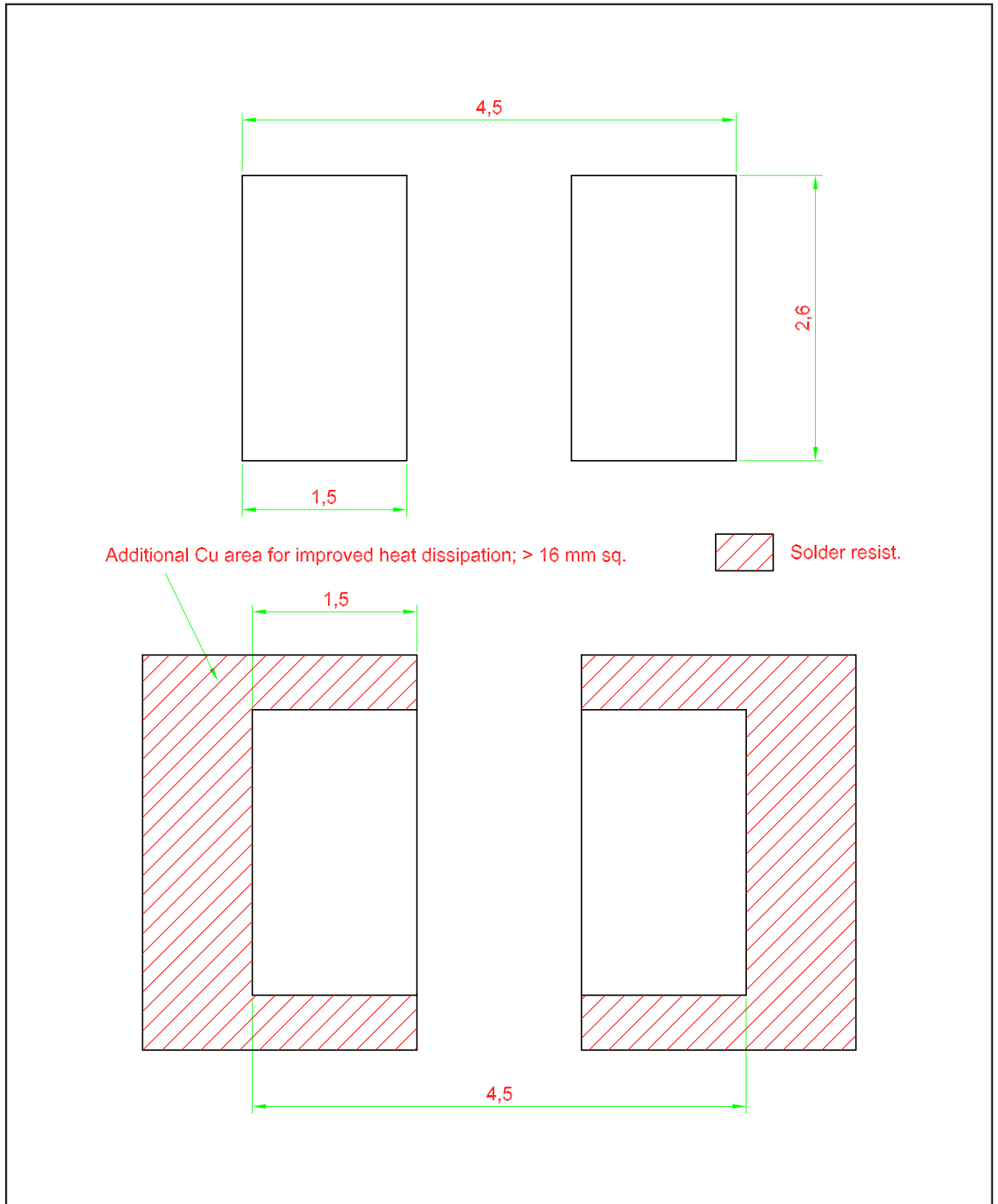

Taping and orientation

- Reels come in quantity of 2000 units.
- Reel diameter is 180 mm.

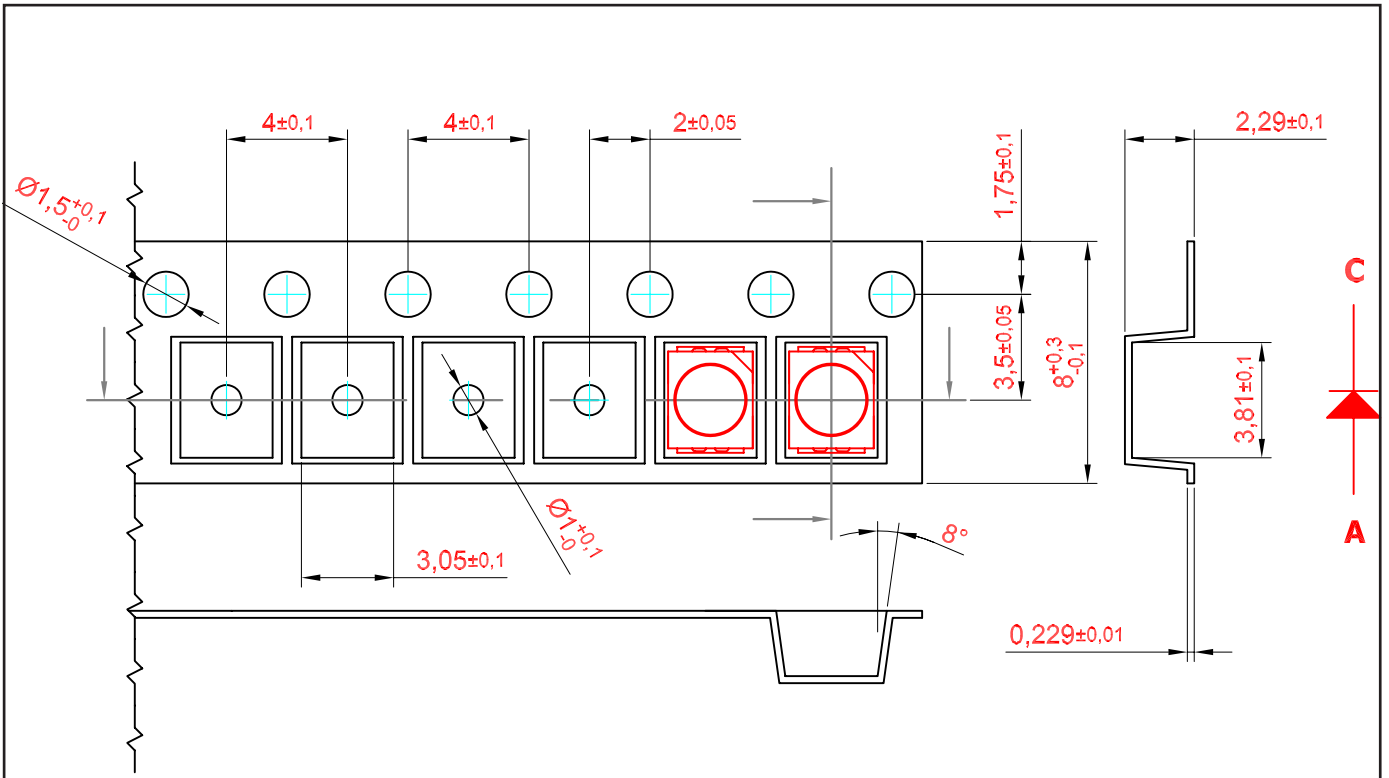

200 mm min. for $\varnothing 180$ reel.
 200 mm min. for $\varnothing 330$ reel.

480 mm min. for $\varnothing 180$ reel.
 960 mm min. for $\varnothing 330$ reel.

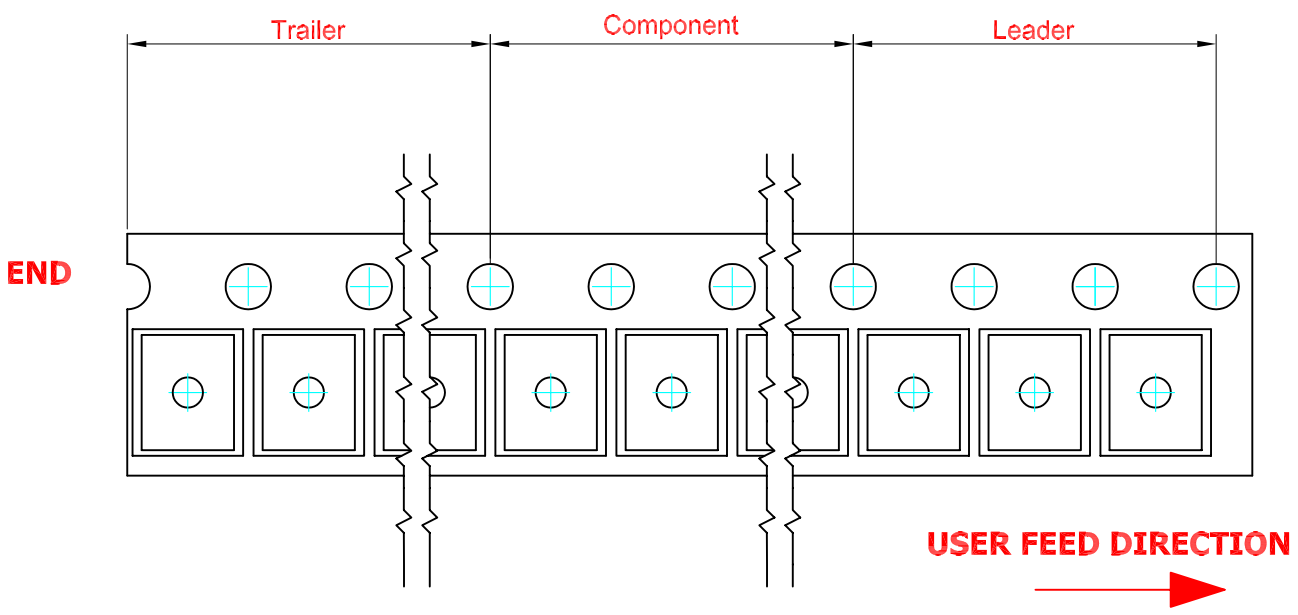

Packaging Specification

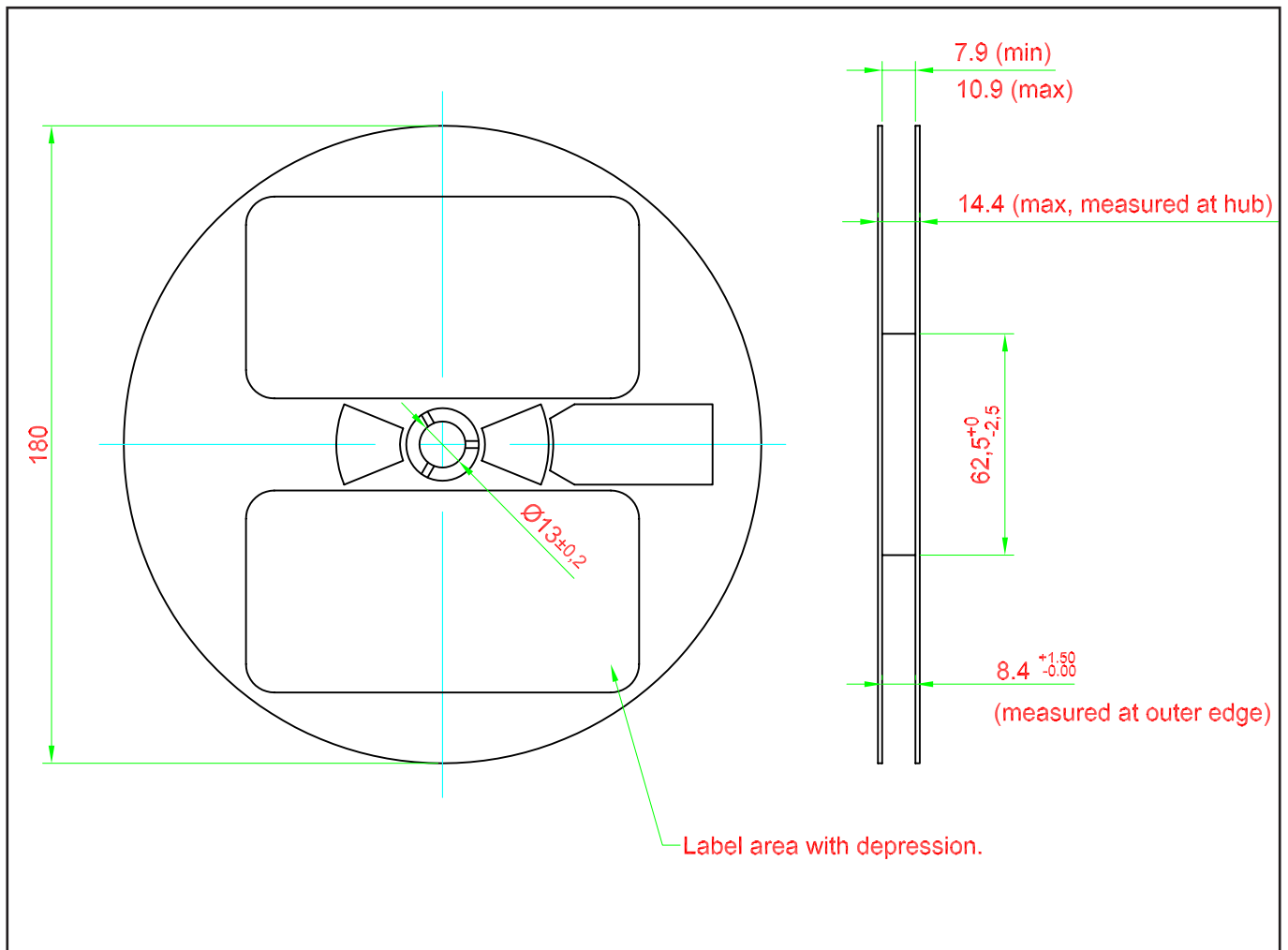

Packaging Specification

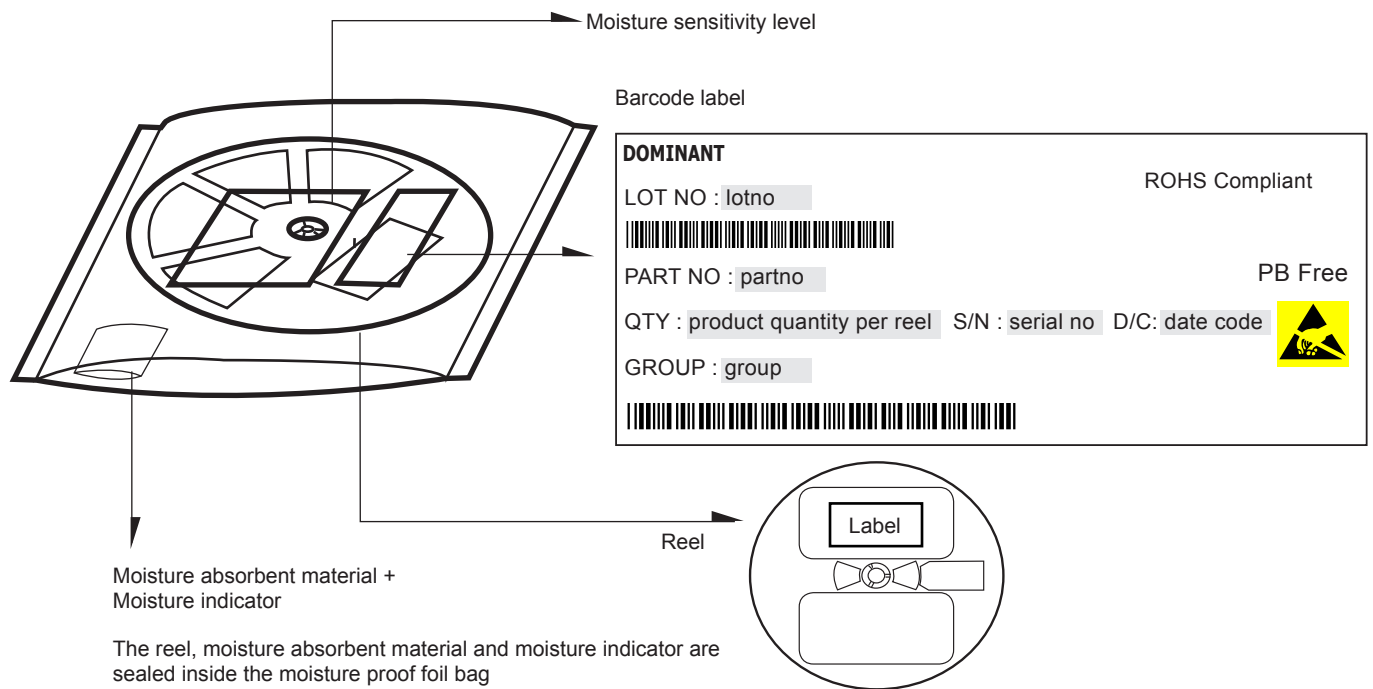

	Average 1pc DomiLED/Multi DomiLED	1 completed bag (2000pcs)
Weight (gram)	0.034	190 ± 10

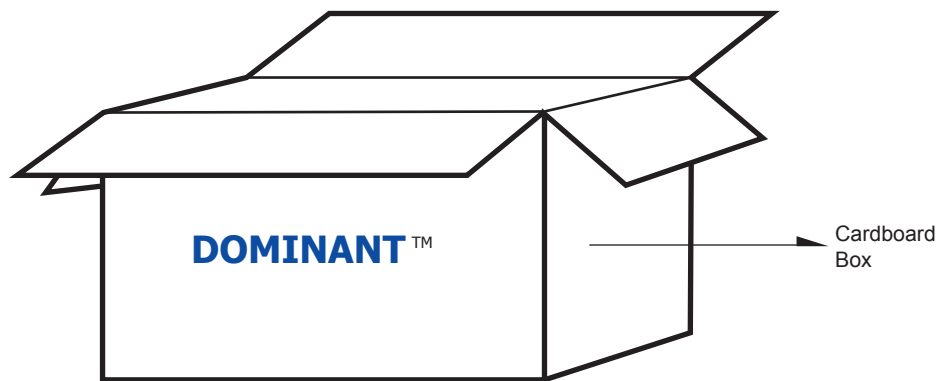

For DomiLED™

Cardboard Box Size	Dimensions (mm)	Empty Box Weight (kg)	Reel / Box	Quantity / Box (pcs)
Small	300 x 250 x 250	0.58	15 reels MAX	30,000 MAX
Large	416 x 516 x 476	1.74	96 reels MAX	192,000 MAX

Recommended Pb-free Soldering Profile

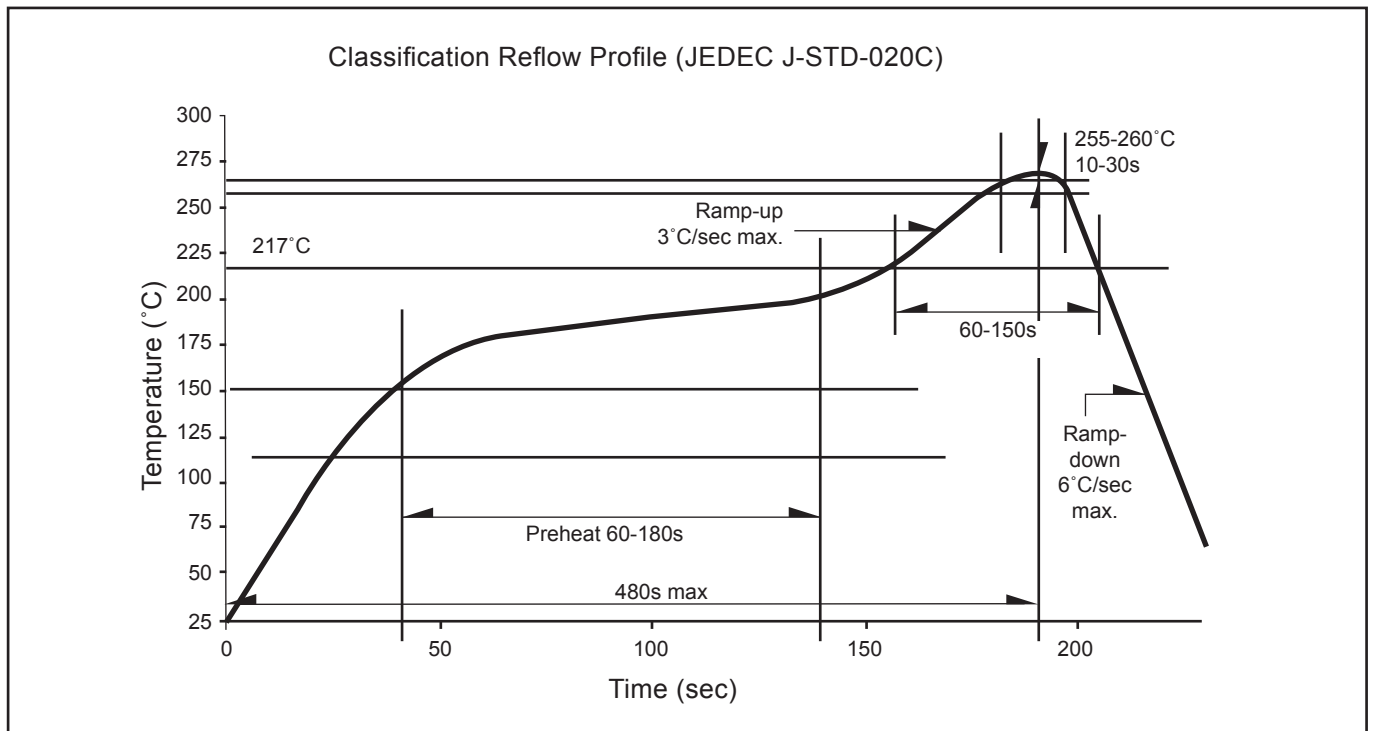

Revision History

Page	Subjects	Date of Modification
-	Initial release	22 Feb 2012
2	Typo error on ESD threshold (HBM)	28 May 2012

NOTE

All the information contained in this document is considered to be reliable at the time of publishing. However, DOMINANT Opto Technologies does not assume any liability arising out of the application or use of any product described herein.

DOMINANT Opto Technologies reserves the right to make changes to any products in order to improve reliability, function or design.

DOMINANT Opto Technologies products are not authorized for use as critical components in life support devices or systems without the express written approval from the Managing Director of DOMINANT Opto Technologies.

About Us

DOMINANT Opto Technologies is a dynamic Malaysian Corporation that is among the world's leading SMT LED Manufacturers. An excellence – driven organization, it offers a comprehensive product range for diverse industries and applications. Featuring an internationally certified quality assurance acclaim, DOMINANT's extra bright LEDs are perfectly suited for various lighting applications in the automotive, consumer and communications as well as industrial sectors. With extensive industry experience and relentless pursuit of innovation, DOMINANT's state-of-art manufacturing, research and testing capabilities have become a trusted and reliable brand across the globe. More information about DOMINANT Opto Technologies can be found on the Internet at <http://www.dominant-semi.com>.

Please contact us for more information:

Head Quarter

DOMINANT Opto Technologies Sdn. Bhd.
Lot 6, Batu Berendam, FTZ Phase III, 75350 Melaka, Malaysia
Tel: (606) 283 3566 Fax: (606) 283 0566
E-mail: sales@dominant-semi.com

DOMINANT Opto Technologies Sdn. Bhd. Shanghai Representative Office

Rm 305, Hongwell International Plaza No. 1600 Zhong Shan(W) Rd, Xuhui District, Shanghai, China 200235
Tel: +86 21 5403 5655, +86 21 5403 5818 Fax: +86 21 5403 6055
E-mail: sales_china@dominant-semi.com

DOMINANT Opto Technologies Sdn. Bhd. Shenzhen Representative Office

Rm 1808, Block B, South International Plaza No 3013, Yitian Road, Futian District, Shenzhen, 518048 P.R. China
Tel: +86 755 8282 1781
E-mail: sales_china@dominant-semi.com

DOMINANT Korea Sales Office

DOMINANT Semiconductors Korea Inc.
RM 211 SUNTEAK CITY APT. 513-15 Sangdaewon-dong, Jungwon-gu, Seongnam-si, Gyeonggi-do, 462-725, Korea
Tel: +82-31-701-5203 Fax: +82-31-701-5204
E-mail: sales_korea@dominant-semi.com

DOMINANT U.S.A Sales Office

25 Rockaway Road, 08833 Lebanon, New Jersey, USA
Tel: (908) 439-9930 Cell: (908) 343-5810 Fax: (908) 439-9929
E-mail: don.wendel@dominant-semi.com

DOMINANT Europe Sales Office

DOMINANT Semiconductors Europe GmbH
Raiffeisenstr. 38, 74906 Bad Rappenau Germany
Tel: +49 (0) 7264-89010-10 / +49 (0) 7264-89010-11 Cell: +49 173-6907370 / +49 173-6907751
Fax: +49 (0) 7264-89010-29
E-mail: gerd.wachno@dominant-semi.eu; hartmut.wettengl@dominant-semi.eu

DOMINANT India Sales Office

C-11, Vasanth Business Centre #86, TTK Road, Alwarpet Chennai - 600 018, INDIA
Tel: 91-44-42030616 / 516 Cell: 91-9444920537 Fax: 91-9444920616
E-mail: pravat.behera@dominant-semi.com

