

Domiled

Synonymous with function and performance, the Domiled series is perfectly suited for a variety of cross-industrial applications due to its small package outline, durability and superior brightness.



Features:

- > High brightness surface mount LED.
- > 120° viewing angle.
- > Small package outline (LxWxH) of 3.2 x 2.8 x 1.8mm.
- > Qualified according to JEDEC moisture sensitivity Level 2.
- > Compatible to IR reflow soldering.
- > Environmental friendly; RoHS compliance.
- > Compliance to automotive standard; AEC-Q101.
- > Passed Corrosion Resistant Test. *Appx. 4.1*



Applications:

- > Automotive: interior applications, eg: switches, telematics, climate control system, dashboard, etc.
- > Exterior applications, eg: signal lighting, Center High Mounted Stop Light (CHMSL)
- > Signage: full color display video notice board, signage, special effect lighting
- > Lighting: channel light



Optical Characteristics at Tj=25°C

Part Ordering Number	Color	Viewing Angle°	Luminous Intensity @ 20mA IV (mcd) <i>Appx. 1.1</i>		
			Min.	Typ.	Max.
● DDS-PJS-U2V-1	Super Red, 632nm	120	560.0	843.0	1125.0
● DDR-PJS-VW1-1	Red, 622 nm	120	715.0	1058.0	1400.0
● DDA-PJS-V2W-1	Amber, 615 nm	120	900.0	1350.0	1800.0
● DDY-PJS-V2W-1	Yellow, 590 nm	120	900.0	1350.0	1800.0
● Not for new design.					

Electrical Characteristics at Tj=25°C

Part Number	Vf @ If = 20mA <i>Appx. 3.1</i>			Vr @ Ir = 10uA <i>Appx. 6.1</i>
	Min. (V)	Typ. (V)	Max. (V)	
DDx-PJS	1.8	2.1	2.6	12

Absolute Maximum Ratings

	Maximum Value	Unit
DC forward current	50	mA
Peak pulse current; (tp ≤ 10µs, Duty cycle = 0.10)	100	mA
Reverse voltage; Ir (max) = 10µA <i>Appx. 6.1</i>	12	V
ESD threshold (HBM)	2	kV
LED junction temperature	125	°C
Operating temperature	-40 ... +115	°C
Storage temperature	-40 ... +125	°C
Power dissipation (at room temperature)	130	mW
Thermal resistance		
- Real Thermal Resistance		
Junction / ambient, R _{th JA real}	360	K/W
Junction / solder point, R _{th JS real}	150	K/W
- Electrical Thermal Resistance		
Junction / ambient, R _{th JA el}	230	K/W
Junction / solder point, R _{th JS el}	95	K/W
(Mounting on FR4 PCB, pad size ≥ 16 mm ² per pad)		

Wavelength Grouping at Tj=25°C

Color	Group	Wavelength distribution (nm) <small>Appx. 2.2</small>
DDS; Super Red	Full	625 - 640
DDR; Red	Full	620 - 630
DDA; Amber	Full	610 - 621
	W	610 - 615
	X	615 - 621
DDY; Yellow	Full	582 - 594
	W	582 - 585
	X	585 - 588
	Y	588 - 591
	Z	591 - 594

Luminous Intensity Group at Tj=25°C

Brightness Group	Luminous Intensity <small>Appx. 1.1</small> IV (mcd)
U2	560.0...715.0
V1	715.0...900.0
V2	900.0...1125.0
W1	1125.0...1400.0
W2	1400.0...1800.0

Vf Bining (Optional)

Vf @ If = 20mA	Forward Voltage (V) <small>Appx. 3.1</small>
V1	1.80 ... 1.95
V2	1.95 ... 2.10
V3	2.10 ... 2.25
V4	2.25 ... 2.40
V5	2.40 ... 2.55
V6	2.55 ... 2.70

Please consult sales and marketing to incorporate special part number to incorporate Vf binning.

Relative Luminous Intensity Vs Forward Current

$I_v/I_v(20\text{mA}) = f(I_F); T_j = 25^\circ\text{C}$

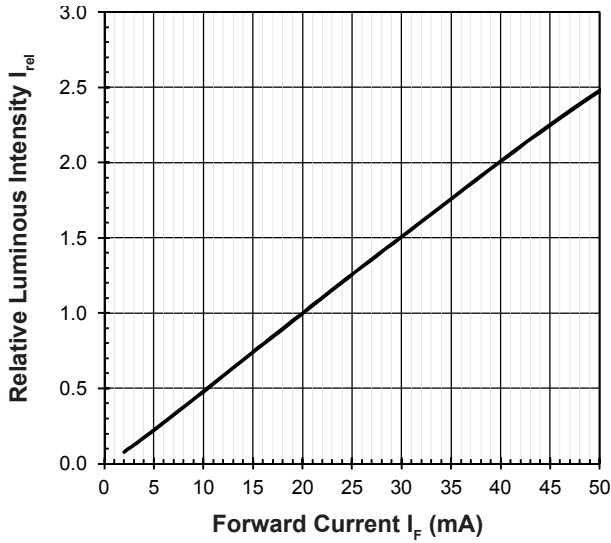

Forward Current Vs Forward Voltage

$I_F = f(V_F); T_j = 25^\circ\text{C}$

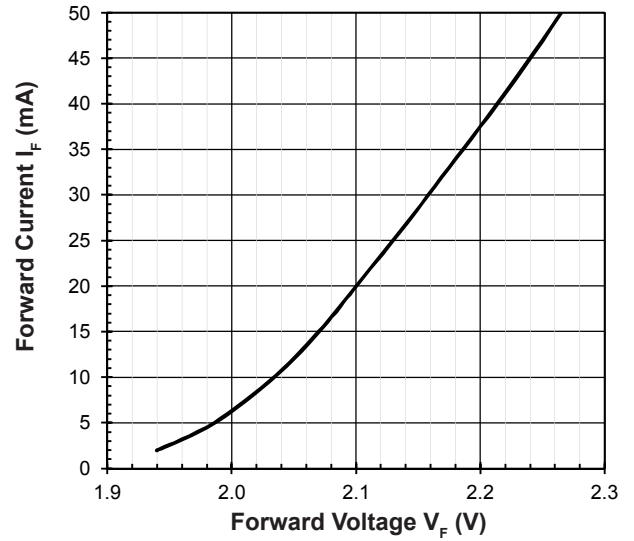

Maximum Current Vs Temperature

$I_F = f(T)$

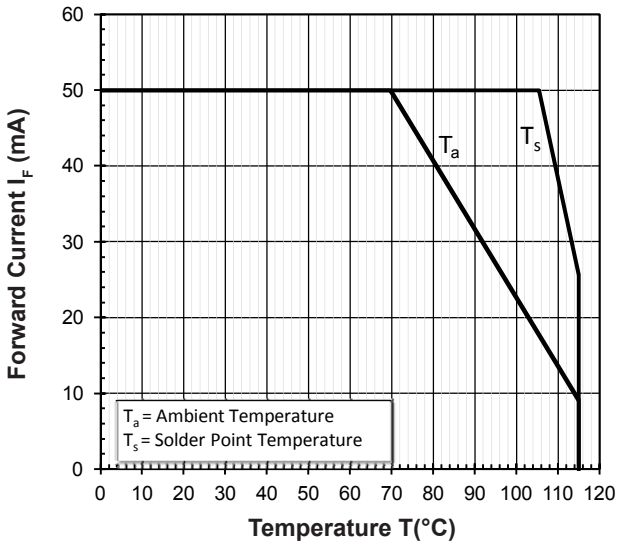

Relative Spectral Emission

$I_{rel} = f(\lambda); T_j = 25^\circ\text{C}; I_F = 20\text{mA}$

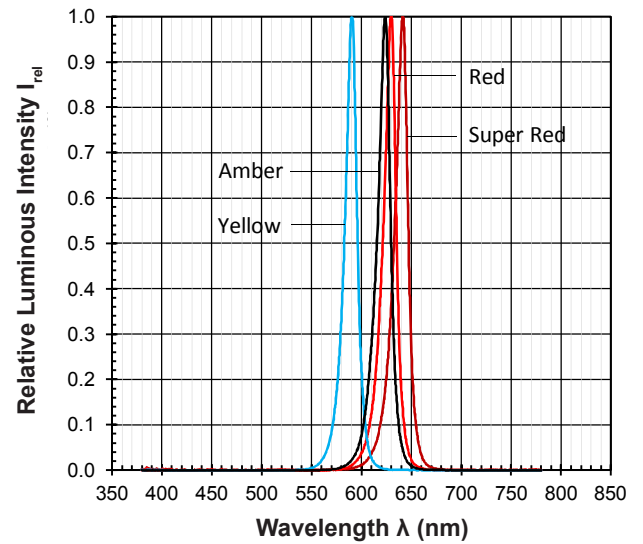

Allowable Forward Current Vs Duty Ratio

$(T_j = 25^\circ\text{C}; t_p \leq 10\mu\text{s})$



Radiation Pattern

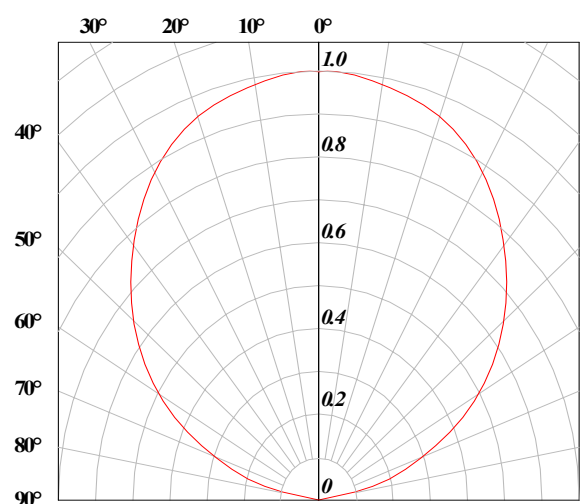

Relative Forward Voltage Vs Junction Temperature

$$\Delta V_F = V_F - V_F(25^\circ\text{C}) = f(T_j); I_F = 20\text{mA}$$

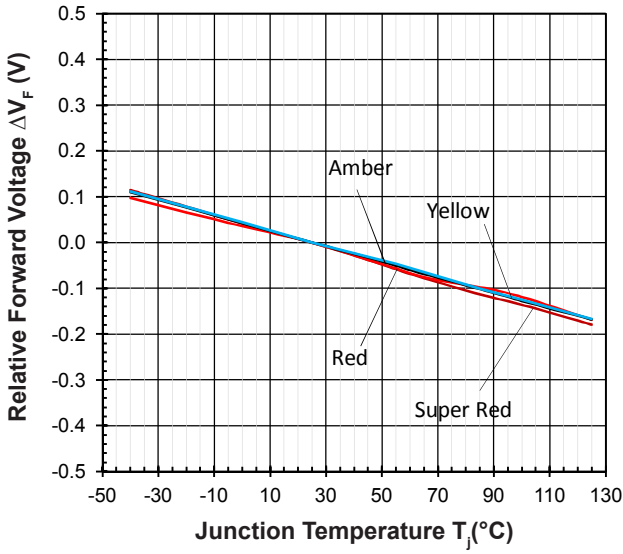

Relative Luminous Intensity Vs Junction Temperature

$$I_V/I_V(25^\circ\text{C}) = f(T_j); I_F = 20\text{mA}$$

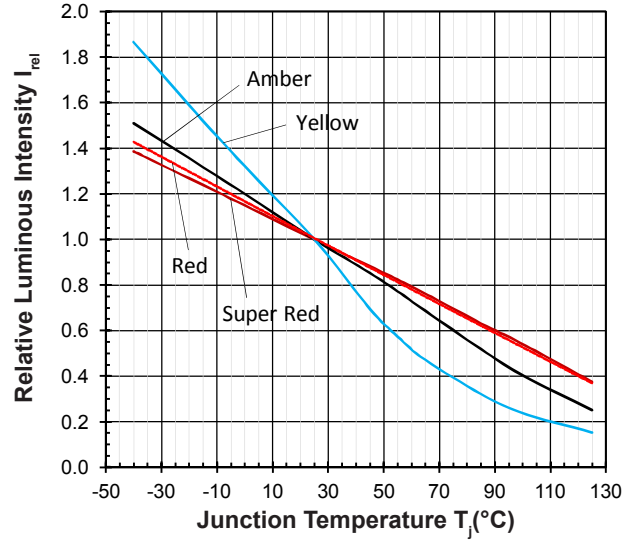

Relative Wavelength Vs Junction Temperature

$$\Delta \lambda_{dom} = \lambda_{dom} - \lambda_{dom}(25^\circ\text{C}) = f(T_j); I_F = 20\text{mA}$$

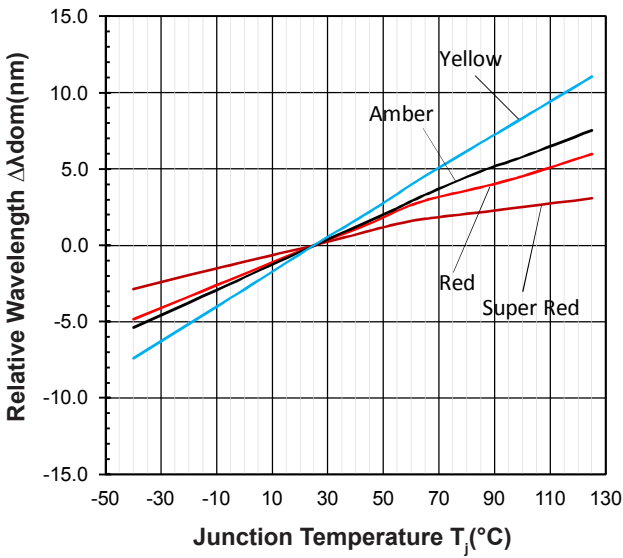

DomiLED • AllnGaP : DDx-PJS Package Outlines

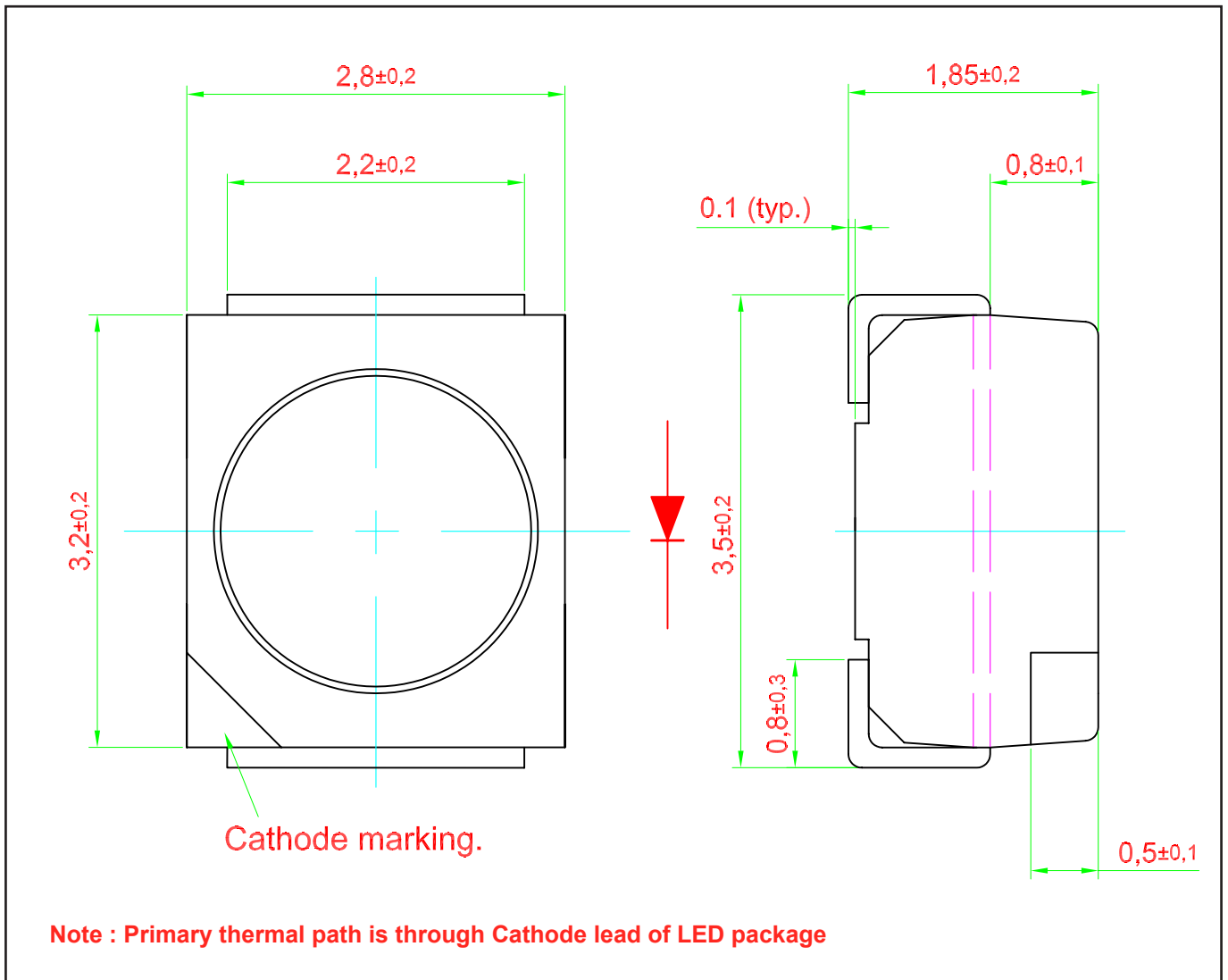

Material

Material	
Lead-frame	Cu Alloy With Ag Plating
Package	High Temperature Resistant Plastic, PPA
Encapsulant	Epoxy
Soldering Leads	Sn-Sn Plating

Recommended Solder Pad

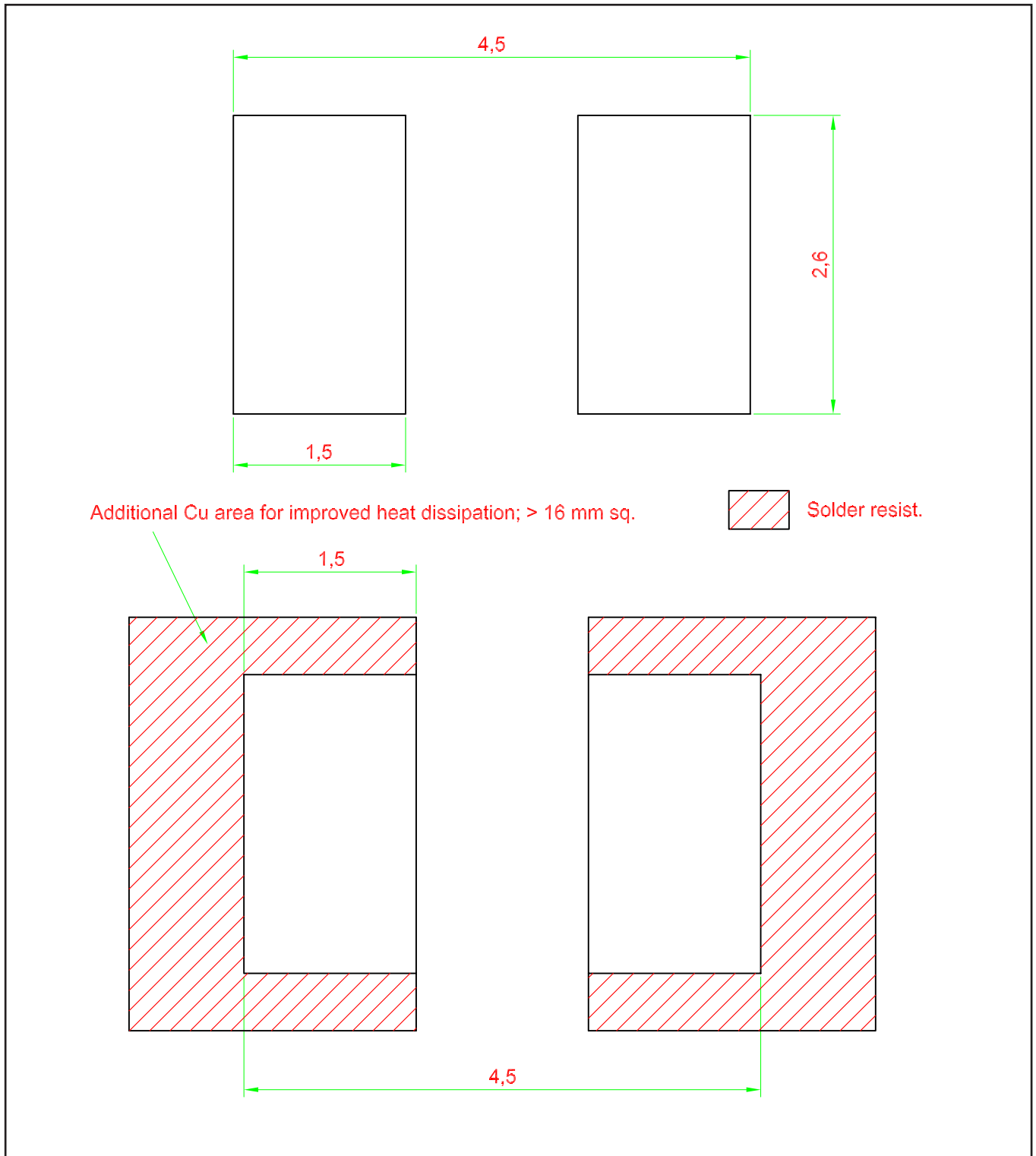

Taping and orientation

- Reels come in quantity of 2000 units.
- Reel diameter is 180 mm.

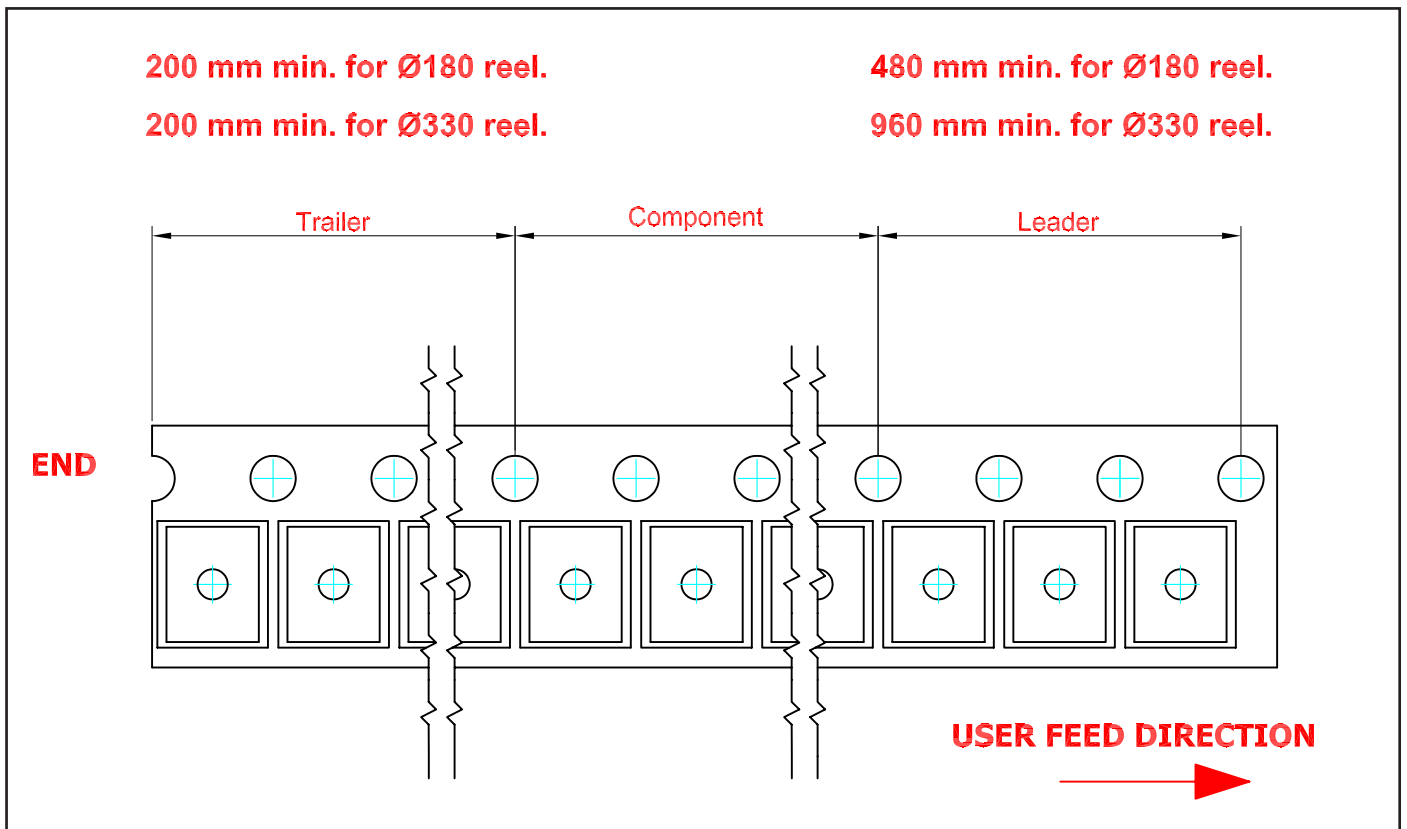
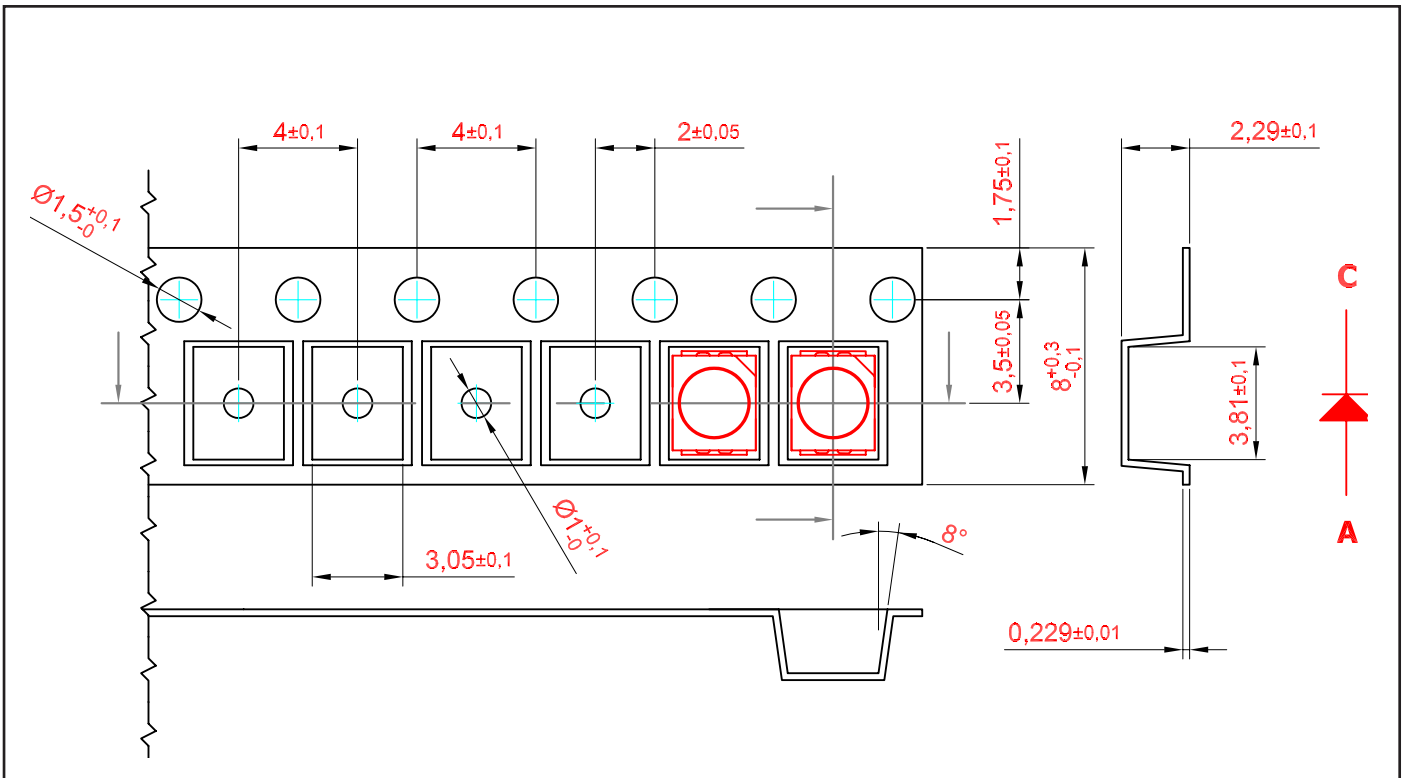

Packaging Specification

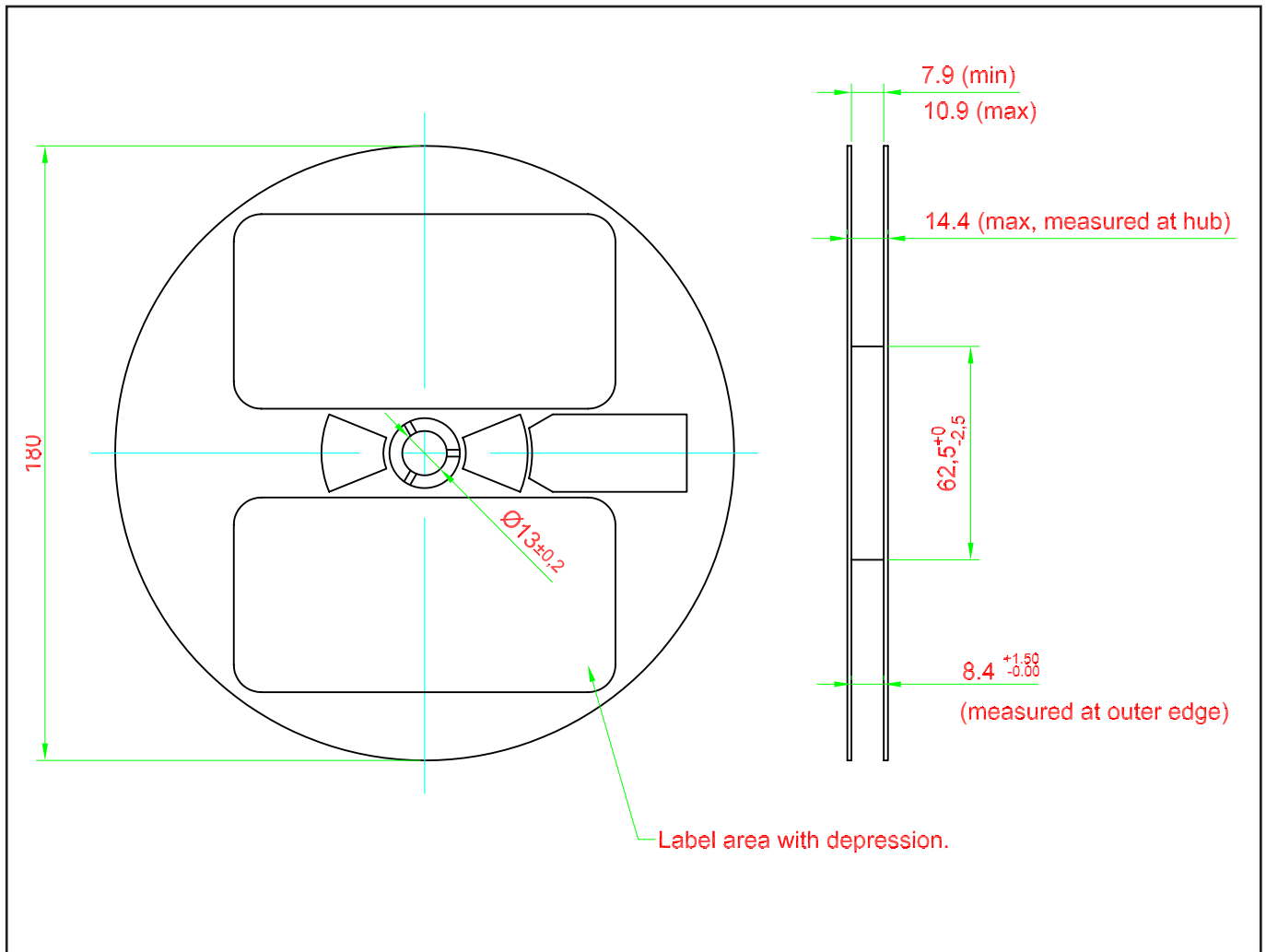

Packaging Specification

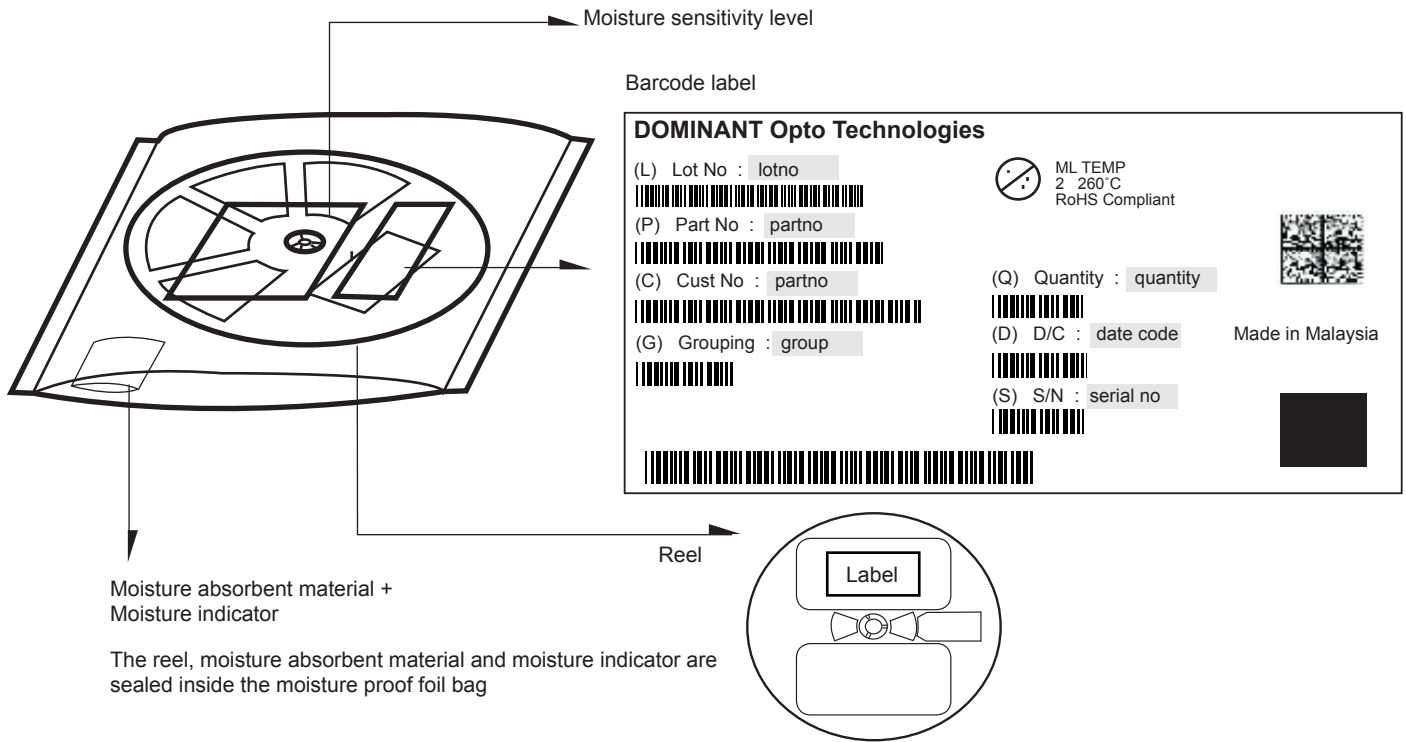

	Average 1pc DomiLED/Multi DomiLED	1 completed bag (2000pcs)
Weight (gram)	0.034	240 ± 10

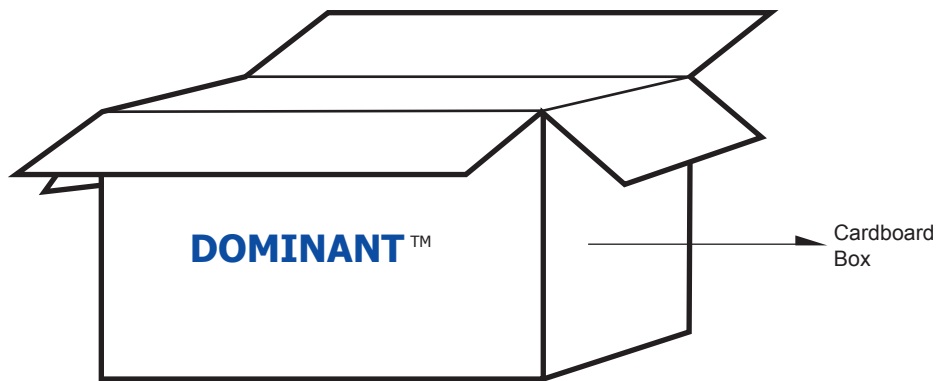

For DomiLED

Cardboard Box Size	Dimensions (mm)	Empty Box Weight (kg)	Reel / Box
Super Small	325 x 225 x 190	0.38	9 reels MAX
Small	325 x 225 x 280	0.54	15 reels MAX
Medium	570 x 440 x 230	1.46	60 reels MAX
Large	570 x 440 x 460	1.92	120 reels MAX

Recommended Pb-free Soldering Profile

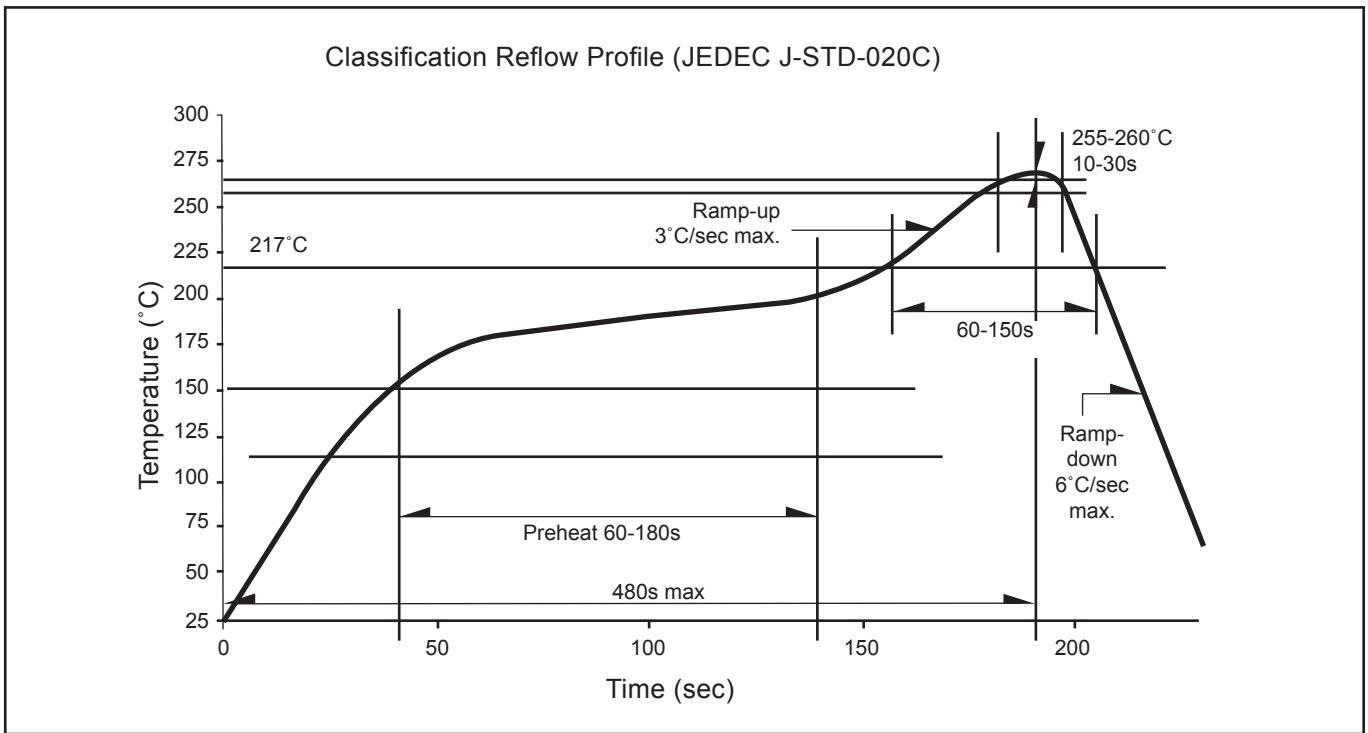

Appendix

1) **Brightness:**

- 1.1 Luminous intensity is measured at current pulse 25 ms(typ) with an internal reproducibility of $\pm 8 \%$ and an expanded uncertainty of $\pm 11 \%$ (according to GUM with a coverage factor of $k=3$).
- 1.2 Luminous flux is measured at current pulse 25 ms(typ) with an internal reproducibility of $\pm 8 \%$ and an expanded uncertainty of $\pm 11 \%$ (according to GUM with a coverage factor of $k=3$).
- 1.3 Radiant intensity is measured at current pulse 25 ms(typ) with an internal reproducibility of $\pm 8 \%$ and an expanded uncertainty of $\pm 11 \%$ (according to GUM with a coverage factor of $k=3$).
- 1.4 Radiant flux is measured at current pulse 25 ms(typ) with an internal reproducibility of $\pm 8 \%$ and an expanded uncertainty of $\pm 11 \%$ (according to GUM with a coverage factor of $k=3$).

2) **Color:**

- 2.1 Chromaticity coordinate groups are measured at current pulse 25 ms(typ) with an internal reproducibility of ± 0.005 and an expanded uncertainty of ± 0.01 (accordingly to GUM with a coverage factor of $k=3$).
- 2.2 Dominant wavelength is measured at current pulse 25 ms(typ) with an internal reproducibility of $\pm 0.5\text{nm}$ and an expanded uncertainty of $\pm 1\text{nm}$ (accordingly to GUM with a coverage factor of $k=3$).

3) **Voltage:**

- 3.1 Forward Voltage, V_f is measured when a current pulse of 8 ms(typ) with an internal reproducibility of $\pm 0.05\text{V}$ and an expanded uncertainty of $\pm 0.1\text{V}$ (accordingly to GUM with a coverage factor of $k=3$).

4) **Typical Values:**

- 4.1 At special conditions of LED manufacturing processes, typical data or calculated correlations of technical parameters only reflect the statistical figures. But not necessarily correspond to the actual parameters of each single product, which could differ from the typical data or calculated correlations or the typical characteristic line. These typical data may change whenever technical improvements happen.

5) **Tolerance of Measure**

- 5.1 Unless otherwise noted in drawing, tolerances are specified with ± 0.1 and dimension are specific in mm.

6) **Reverse Voltage:**

- 6.1 Not designed for reverse operation. Continuous reverse voltage can cause migration and LED damage.

Revision History

Page	Subjects	Date of Modification
-	Initial Release	11 Mar 2011
2, 3	Add Thermal Resistance Data & Characteristics	02 Nov 2011
2	Update Absolute Maximum Ratings: ESD threshold (HBM) Add new partno: DDS-PJS-U2V-1	05 Jan 2012
2	Update Operating Temperature and Storage Temperature	04 Dec 2012
4	Add Vf Binning	21 Feb 2014
1, 5, 6, 10	Add Features Update Graph: Relative Intensity Vs Forward Current Add Notes in Packaging Outline Update Packaging Specification	30 Oct 2015
1, 2, 5, 6, 13	Update Features Update Product Photo Add Electrical Thermal Resistance Update LED Junction Temperature Update Graph Add Appendix	07 Nov 2016
2, 13	Not for New Design: DDS-PJS-U2V-1, DDR-PJS-VW1-1, DDA-PJS-V2W-1, DDY-PJS-V2W-1 Update Appendix	16 Mar 2018

NOTE

All the information contained in this document is considered to be reliable at the time of publishing. However, DOMINANT Opto Technologies does not assume any liability arising out of the application or use of any product described herein.

DOMINANT Opto Technologies reserves the right to make changes to any products in order to improve reliability, function or design.

DOMINANT Opto Technologies products are not authorized for use as critical components in life support devices or systems without the express written approval from the Managing Director of DOMINANT Opto Technologies.

About Us

DOMINANT Opto Technologies is a dynamic company that is amongst the world's leading automotive LED manufacturers. With an extensive industry experience and relentless pursuit of innovation, DOMINANT's state-of-art manufacturing and development capabilities have become a trusted and reliable brand across the globe. More information about DOMINANT Opto Technologies, a ISO/TS 16949 and ISO 14001 certified company, can be found under <http://www.dominant-semi.com>.

Please contact us for more information:

DOMINANT Opto Technologies Sdn. Bhd
Lot 6, Batu Berendam, FTZ Phase III, 75350 Melaka, Malaysia.
Tel: +606 283 3566 Fax: +606 283 0566
E-mail: sales@dominant-semi.com
